



< BACK

IN DEPTH



## Dead-tank breakers without need of additional capacitors

01/11/2016 - 4.36 pm

 **CIRCUIT BREAKERS**  **GRID RELIABILITY & EFFICIENCY**

*Line-to-ground capacitors are used to alter transient recovery voltages and allow circuit breakers to interrupt fault currents. Eliminating them enables substation design to be simplified, maintenance to be reduced, and overall substation costs to be cut.*



**2 comments**



Sometimes a solution can create new problems. That's exactly the case when dealing with short-line faults. These are faults occurring on an overhead transmission line a few hundred meters to a few kilometers away from the circuit breaker terminals. The fault condition is characterized by a very rapidly rising voltage called Transient Recovery Voltage (TRV) across the breaker contacts that occurs a very short time after current interruption.

Transient currents and voltages are generated while closing or opening the electrical contacts associated with the circuit breaker, including disconnecter switches. They are short-lived (typically less than one cycle) and may be repetitive due to the relatively slower movement of the disconnecter switch blade. The traditional solution to deal with TRVs is to install line-to-ground capacitors on one or both sides of the circuit breaker to modify the delay and rise times of the transient voltage.



### *Circuit Breaker with Free-Standing Capacitors*

Circuit breakers are usually divided into two families: “Live Tank” and “Dead Tank” units. Dead-tank circuit breakers are usually grounded through jumpers connecting the terminal pads on the structure to the substation grounding grid. During closing, the equivalent capacitance of the substation behind the disconnect switch feeds the transient into the line-to-ground capacitors through the disconnect switch. During opening, the disconnect switch has to break the load current of the capacitor and can experience multiple restrikes until the distance between the jaw(s) and the blade are sufficient to withstand the voltage appearing across them. Within the circuit breaker, the path to ground normally consists of multiple trajectories including tanks, structural elements, welds and bolted connections. Victor Hermosillo, Grid Solutions R&D Manager, explains: “In a traditional design additional measures are included to control the path and prevent arcing between components, damage to components inside the circuit breaker control cabinet, coupling into control wiring, and transients transmitted into the control house.”

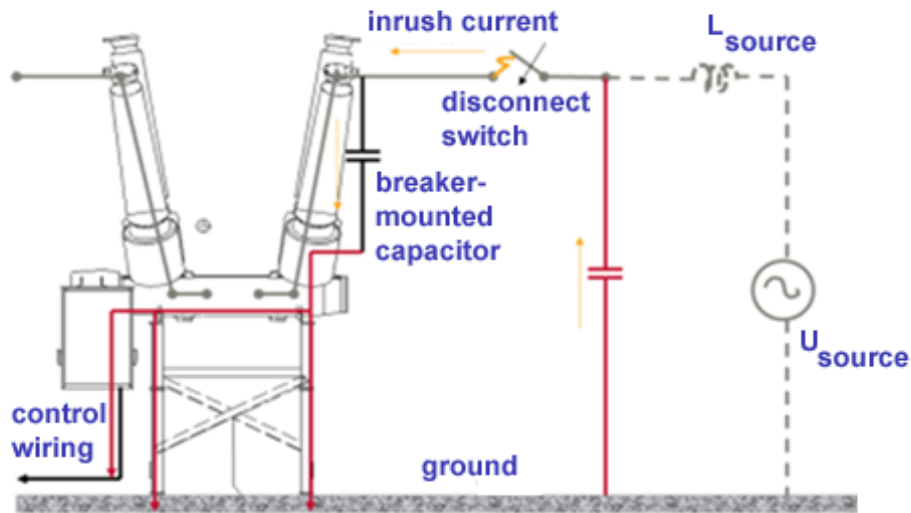

*Condition leading to transients during the energizing of breaker-mounted line-to-ground capacitors*

## 1 \_\_ Eliminate the need for additional capacitors



The usual response is to mount capacitors on the circuit breaker to control the flow of the currents via separate conductors between the circuit breaker tanks and an additional conductor between one tank and the grounding pad on the structure. These grounding elements can be connected to some of the breaker elements along their path or can be entirely isolated. Both approaches have their drawbacks. Mounted parallel to the circuit breaker, the extra weight of the capacitor requires increasing the capacity of support structures and foundations. Free-standing capacitors require additional space in the substation as well as added structures, terminals and foundations.

For Hermosillo, the Grid Solutions DT1-145 63 dead-tank circuit breaker, jointly developed by teams in the US and France, is the

way forward. The new design breaks from previous configurations by removing the need to install adjacent capacitors. “Although eliminating the need for line-to-ground capacitors, the new DT1-145 63 withstands the transient currents and voltages generated during switching operations, and minimizes their effect on substation equipment.”



*Dead-tank circuit breaker rated 145 kV, 63 kA, 60 Hz*

## 2 \_\_ New self-blast, double-motion interrupter technology



---

A spring-based FK 3-4 type mechanism and third-generation SF<sub>6</sub> self-blast, non-linear double-motion interrupter technology have now been applied to the DT1-145 63. Each pole includes one single-pressure, partial dual-flow design interrupter and uses a combination of SF<sub>6</sub> gas puffer action and self-blast/thermal action for interruption. When the current is interrupted, a transition from the conductive to the insulating state occurs within a few milliseconds.

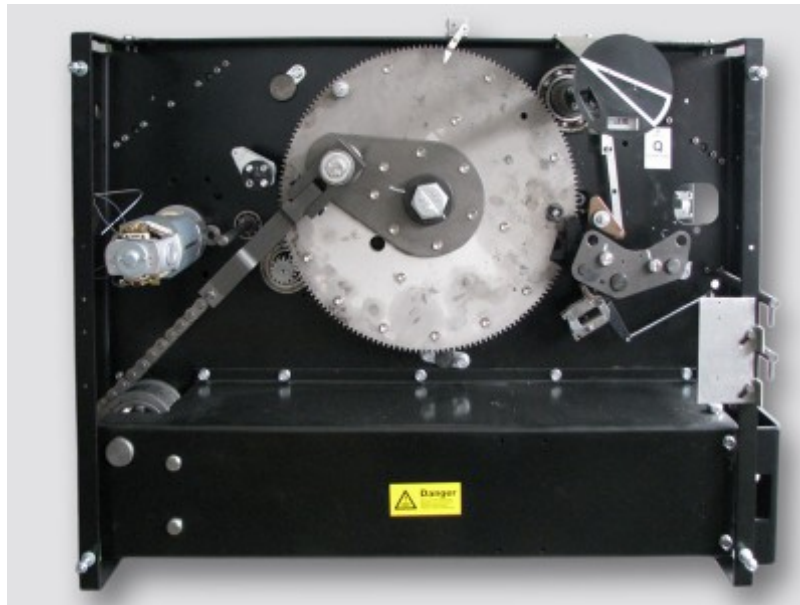

### *Low-energy FK3-4 mechanism*

During opening, an arc forms across the arcing contacts of the interrupter. Nozzles encapsulate the arcing contacts, which direct gas flow across the arc. The gas flow developed within the interrupter unit quenches the arc. Smaller currents, with values in the range of the continuous current rating of the circuit breaker, are interrupted by puffer action, which consists of a piston compressing an SF<sub>6</sub> gas volume inside a cylinder. Higher currents, up to the rated short-circuit current, are interrupted by self-blast action. Intermediate currents are interrupted by a combination of puffer and self-blast action. The operating mechanism supplies the energy for contact movement and for compression of the puffer volume. The double-motion technology of the interrupter has the advantage of decreasing the amount of energy required to operate the breaker and decreasing the kinematic energy of moving parts.

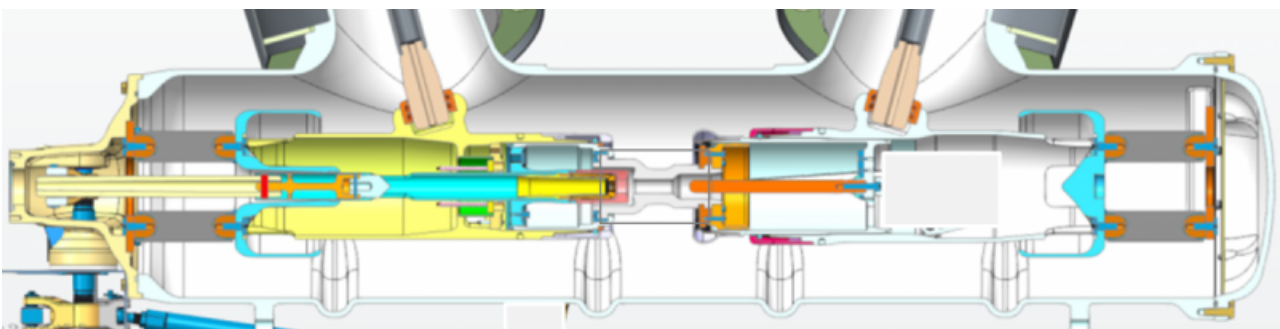

### 3 \_\_ Industrialization and testing



---

Each pole unit consists of a cylindrical aluminum tank containing one built-in, electrically insulated interrupter unit, two porcelain or composite bushings for insulating line voltage from ground, and current transformers. Pockets on the top of both ends of the tank contain doughnut-type current transformers. The mobile contacts of the interrupter unit are connected to the operating mechanism by insulating rods, shafts and levers internal to each pole, and externally via a common mechanical linkage system.

The tank is formed from a single-piece aluminum casting. This reduces potential for leaks, compared to tanks of several pieces requiring additional sealing surfaces. In addition, each circuit breaker is tested using Grid Solutions' proprietary gas-tightness testing system, which provides quantifiable test results on the breaker in its fully assembled, as-shipped condition.

Short-line fault tests on the DT1-145 63 for ratings of 145 kV, 63 kA, 60Hz at 90% and 75% of the maximum rated short-circuit current show the benefits of the new design. The increased opening speed leads to longer gap distances in the interrupter, giving lower electric field intensity across the gap. Effective pressure rise in the thermal volume promotes mass and heat flow away from the arcing region. Optimal gas flow in the thermal volume and downstream hot gas exhaust path helps to obtain adequate conditions across the interrupter gap during the first microseconds after current zero.

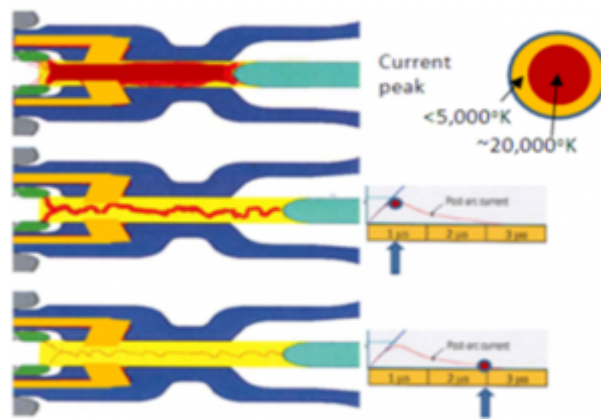

*Conditions across the interrupter gap prior and after current zero crossing*

## 4 Safer and more cost-effective



The DT1-145 63 design integrates safety and cost-effectiveness criteria, too. All linkages and shafts are enclosed inside a cover that prevents personnel from touching any moving parts. Breaking chambers are factory assembled and may be replaced as complete assemblies. The key interrupter sub-components, consisting of the mobile contact assemblies and stationary arcing contacts, may be replaced individually.

As Hermosillo puts it, electrical and mechanical engineering is only part of the story. “We also pay attention to who is going to install and operate the equipment, where and for how long. The DT1-145 63 is factory tested and adjusted and does not require any special tools for installation. On-site installation takes only a few simple steps and it is easy to operate. Moreover, thanks to its low energy mechanism and lifetime lubricants, the DT1 series is virtually maintenance-free, even in severe environmental conditions.”





*DT1-145 63 during Power Tests at CERDA in Villeurbanne, France*

## RATE THIS ARTICLE



---

## COMMENTS



2 comments



SIGN UP FOR OUR NEWSLETTER >

---

## LEARN MORE



---

## EXPERTS



**Victor Hermosillo**

*Grid Solutions – Manager R&D*

---

## SEND A MESSAGE TO OUR EXPERTS



---

[CONTACT US](#)

[LEGAL NOTICE](#)

[PRIVACY](#)

[COOKIES](#)

